

DLC1248-1CC350 control unit

DLC1248-1CC500 control unit

One-channel control unit with ON/OFF and DIMMER function for 350mA or 500mA constant voltage monochrome LEDs. control system via a normally open button. Possibility to expand the system with the use of DLA1248-1CC350 or DLA1248-1CC500 amplifiers. Can be installed in unshielded indoor environments. Memory function possible.

Power supply voltage: $V_{in} = 24Vdc$

Output current: 350mA - 500mA

Power rating: 8.4W@350mA Total - 12W@500mA Total

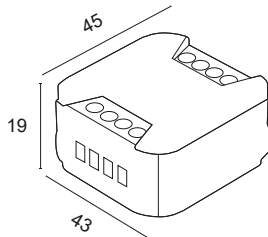

DLC1248-1CC350
DLC1248-1CC500



DLA1248-1CC350
DLA1248-1CC500



EXAMPLE OF MONOCHROME LED SPOTLIGHT CONTROL

- Connected to 5V = MEMORY
- Connected to 5V = NO MEMORY

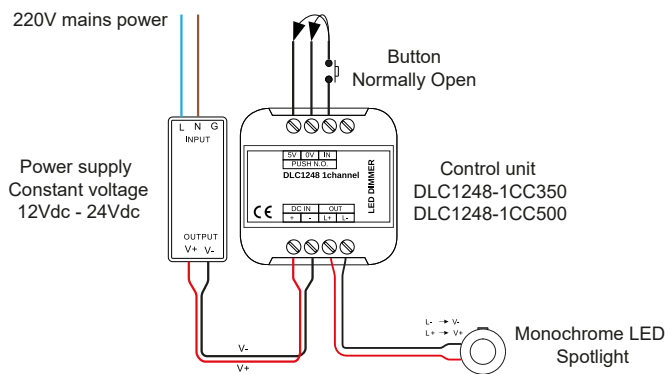

CENTRALINA DLC1248-1CC350-500

EXAMPLE OF MONOCHROME LED SPOTLIGHT CONTROL WITH AMPLIFIER

- Connected to 5V = MEMORY
- Connected to 5V = NO MEMORY

